

An Identity Group Company

**GUEST ROOM NUMBER AND ROOM IDENTIFICATION INSTALLATION**

The preferred location for ADA compliancy is on the wall adjacent to the latch side of the door followed by nearest adjacent wall. If double doors are present (both active), the sign should be located on the right hand side of the right door. If only one door is active, the sign should be located on the other door. Signs with tactile characters shall be permitted on the push side of doors with closers and without hold-open devices (i.e. - Restrooms, Guest rooms).

**PEEPHOLES NOTE:** Center sign vertically between peepholes if room is accessible. If room is not accessible mount Evacuation Plan 2" below peephole

**CALIFORNIA EVACS** (guest room) are to be mounted no higher than 48" to the bottom of the sign, above finished floor

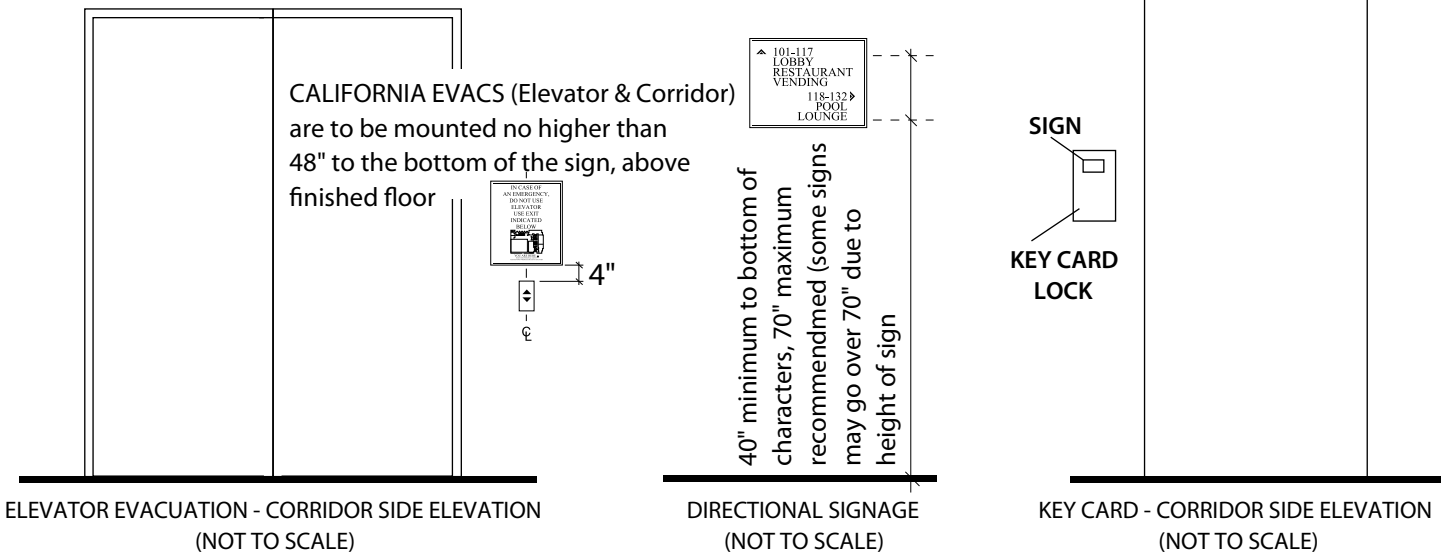
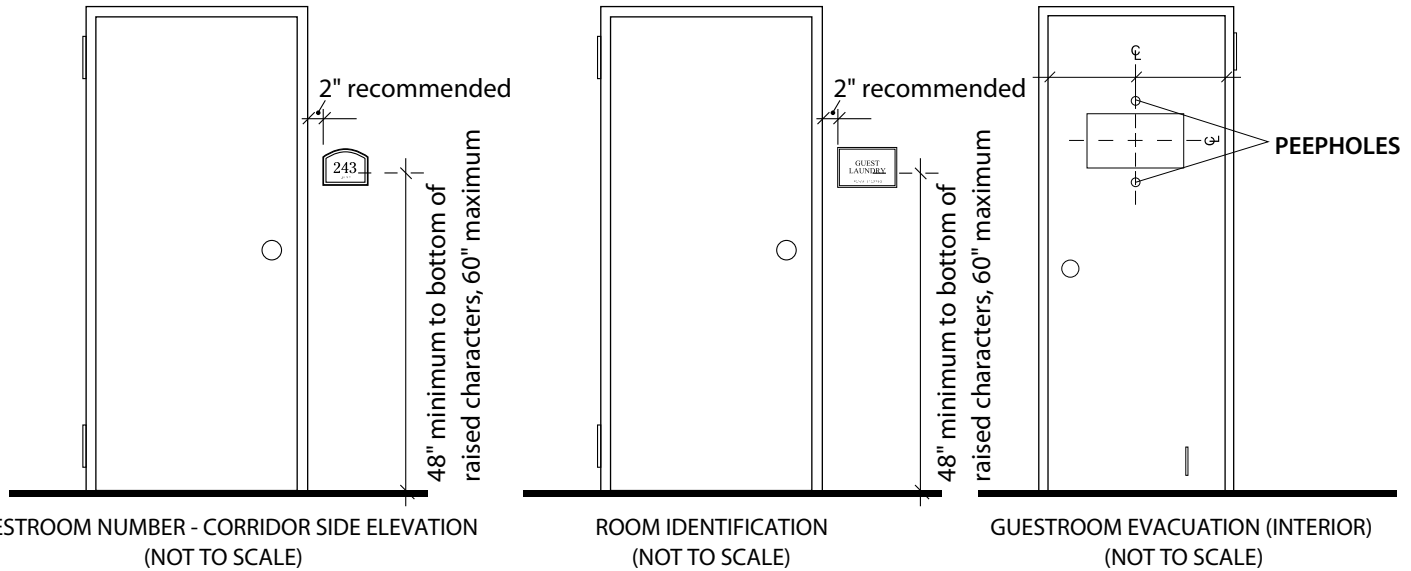

**VINYL BLOCKER FOR GLASS MOUNTING**

Signage that will be mounted on glass will require a vinyl blocker to hide the signage mounting tape and silicone adhesive. The vinyl blocker is mounted to the glass. The signage is mounted on top of the vinyl blocker.

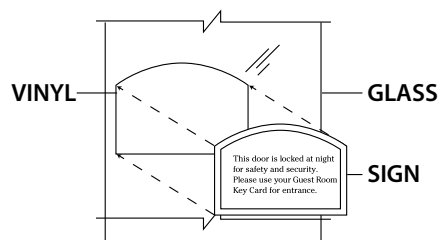



# Signage Mounting Instructions

1. Installation surface must be CLEAN and DUST FREE.
2. Place a small "dot" of silicone in each corner of the sign. The "dot" should be 1/4" to 3/8" in diameter.

**WARNING! FOR PRODUCTS WITH METALLIC CONTENT** (brass, aluminum, silver, gold, copper, etc.) **USE ONLY NON-CORROSIVE SILICONE FOR PRODUCT INSTALLATION!** We recommend Silicone XL by M-D (Macklanburg-Duncan) which is regarded as non-corrosive to metals. **USE OF REGULAR SILICONE OR OTHER LIQUID ADHESIVES WILL VOID ANY/ALL EXPRESSED OR IMPLIED PRODUCT WARRANTIES REGARDING OXIDATION OF THE METALLIC CONTENT.**

3. Remove paper backing from foam tape.
4. Position sign in desired location and apply enough pressure to ensure the foam tape sticks to the mounting surface. The foam tape will hold the sign in place until the silicone adhesive cures.
5. If removal is required, slide a putty knife gently behind the sign and "cut" through the silicone adhesive and the foam tape.

**Signs MUST be Mounted with Foam Tape AND Silicone**

---

**Tape Holds Sign Until Silicone Dries**

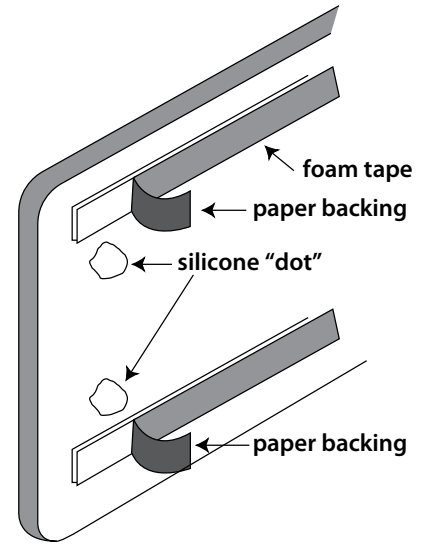

If you have any questions concerning these instructions or problems with signage installation, call 316-267-4171 for assistance.

# Signage Cleaning Instructions

Do NOT clean unless signage appears soiled.

Do NOT use solvents or ammonia based cleaners. Use of such cleaners will void all warranties.

Use a clean, damp, non-abrasive, lint free cloth to wipe the sign surface.

Do NOT immerse sign. Excess water will damage interior grade Braille signage.

When the soil has been removed, wipe the sign with a clean, dry, non-abrasive, lint free cloth.

If you have any questions concerning these instructions, call your account executive at 316-267-4171 for assistance.